

NOVA

DVR Wireless Remote

Instruction Manual



Publication 119-0812-005

FC CE

Z157

NOVA DVR Wireless Remote

Features:

- Fits on any “**Remote Ready**” NOVA DVR Wood Lathe.
- Wireless control convenience at your fingertips.
- Start, stop and speed adjustments.
- Suitably sized buttons for rapid reference and control.
- Use the wireless remote as a wristwatch or remove the strap to attach it magnetically to your NOVA DVR Wood Lathe.
- Invaluable for long spindle work or large platters/bowls when you can't be close to the headstock.
- 2.4 GHz Radio Frequency (RF) operation (FCC Compliant).
- Range up to 23 feet line of sight.
- Up to 3 years stand-by battery life.
- Up to 2 years battery life with up to 20 commands per day.
- 1-Year warranty.

NOTE:

- All values are approximate and calculated under the specific test conditions. For end users, these values might be varied according to workshop conditions, other electronic equipment interference, battery types and operation distance, etc.
- Wireless Remote may not be available in all countries/markets or may require an additional optional accessory Retro Fit Kit for older DVR lathes. See our website or your NOVA Retailer for more information.

FCC STATEMENT

This device complies with Part 15 of the FCC Rules. Operation is subject to the following two conditions:

- (1). This device may not cause harmful interference, and
- (2). This device must accept any interference received, including interference that may cause undesired operation.

Note:

Changes or modifications not expressly approved by the party responsible for compliance could void the user's authority to operate the equipment



Contact Teknatool

New Zealand

Teknatool International Ltd

Phone: (+64) 9 477 5600

Fax: (+64) 9 477 5601

Email: service@teknatool.com

Website: www.teknatool.com

Carbatec New Zealand

Phone: 0800 444 329

Email: sales@carbatec.co.nz

Website: www.carbatec.co.nz

United States

Teknatool Service Center

Phone: 727-346-4775

Email: service@teknatool.com

Website: www.teknatool.com

Woodcraft Supply Corp

Technical Service: 1-800-535-4486

Orders: 1-800-225-1153

Website: www.woodcraft.com

Australia

Carbatec Australia

Phone: +61 7 3397 2577

Free Fax: +61 7 3390 5280

Email: sales@carbatec.com.au

Website: www.carbatec.com.au

Canada

KMS Tools and Equipment Ltd

Phone: (+1) 604-522-5599

Free Phone: 1-800-567-8979

Fax: (+1) 604-522-0638

Email: kmstools@kmstools.com

Website: www.kmstools.com

Netherlands

Baptist voor Houtbewerkers

Tel: 026 445 16 44

Website: <http://www.baptist.nl>

United Kingdom

Record Power

Phone: (+44) 0870 770 1777

Fax: (+44) 0870 770 1888

Website: www.recordpower.co.uk

Austria

Neureiter

Phone: +43 6244 202 99

Fax: +43 6244 202 9910

Email: kontakt@neureiter-maschinen.at

France

OTELO

Phone: 0.800 33 11 11

Fax: 01 39 72 16 60

Website: www.otelo.fr

MAISON DU TOURNAGE

Phone: +33-467-232-852

Fax +33-467-230-038

Email:

relations.maison.du.tournage@wanadoo.fr

Norway

VERKTOY AS

Phone: 0047-51-88-68-00

Fax: 0047-51-88-68-10

Email: post@verktoyas.no

Website: www.verktoyas.no

Belgium

Willy Vanhoutte BVBA

Phone +32 (50) 78 17 94

Fax + 32 (50) 78 19 64

Email: info@willyvanhoutte.be

Website: <http://www.willyvanhoutte.be>

South Africa

The Hardware Centre

Phone: (27) 011 791 0844

Fax: (27) 011 791 0850

Website: www.hardwarecentre.co.za

Email: info@hardwarecentre.co.za

Table of Contents:

GENERAL SAFETY RULES	5
ADDITIONAL SAFETY RULES:.....	7
Installation Instructions:.....	8
Remote Button Layout:.....	13
Operating instructions:	14
Troubleshooting:	15
Battery Replacement:	15
DVR Remote Pairing Instructions	15

© Copyright 2001-2012 by Teknatool International; All Rights Reserved.
Nova DVR is a trademark of Teknatool International Ltd.

The information and specifications contained herein are subject to change. Teknatool is not responsible for errors or omissions herein or for incidental damages in connection with the furnishing or use of this information.

GENERAL SAFETY RULES



Warning! Failure to follow these rules may result in serious personal injury.

IMPORTANT: THIS REMOTE IS NOT INTENDED FOR USE AS AN EMERGENCY DEVICE AND SHOULD NOT BE RELIED UPON AS SUCH

1. **FOR YOUR OWN SAFETY, READ THE MANUAL BEFORE OPERATING THE TOOL.** Learn the machine's application, limitations and the specific hazards particular to it.
2. **ALWAYS USE A FULL FACE SHIELD. Strongly recommended.** (Must comply with ANSI STANDARD Z87.1 -USA) Everyday eye-glasses usually are only impact resistant and safety glasses only protect eyes. A full face shield will protect the eyes and face. Also use face or dust mask if cutting operation is dusty.
3. **WEAR PROPER APPAREL.** Do not wear loose clothing, gloves, neckties, rings, bracelets or other jewelry which may get caught in moving parts. Non-slip footwear is recommended. Wear protective hair covering to contain long hair.
4. **USE EAR PROTECTORS.** Use ear plugs or muffs for any period of operation. Use muffs rated to 103 DBA LEQ (8 hour).
5. **DON'T USE IN DANGEROUS ENVIRONMENT.** Don't use power tools in damp or wet locations, or expose them to rain. Keep work area well lighted. The DVR Wood Lathe is intended for indoor use only. Failure to do so may void the warranty.
6. **KEEP WORK AREA CLEAN.** Cluttered areas and benches invite accidents. Build-up of sawdust is a fire hazard.
7. **KEEP CHILDREN AND VISITORS AWAY.** The Nova DVR is **not recommended** for children or the infirm. Such personnel and onlookers should be kept at a safe distance from the work area.
8. **MAKE WORKSHOP CHILDPROOF.** Utilize locks, master switches, or by removing starter/lockout keys.
9. **GROUND ALL TOOLS.** If the tool is equipped with a three-prong plug, it should be plugged into a three hole electrical receptacle. If an adapter is used to accommodate a two prong receptacle, the adapter plug must be attached to a known ground. **NEVER** remove the third or grounding prong.
10. **DISCONNECT TOOLS.** Ensure the plug is removed from the wall socket before servicing and when changing accessories such as blades, bits, cutters and fuses, etc.
11. **AVOID ACCIDENTAL STARTING.** Make sure switch is in the **Off** position before plugging in power cord into the wall socket.

12. **NEVER LEAVE MACHINE RUNNING UNATTENDED.** Do not leave machine unless it is turned off and has come to a complete stop.
13. **KEEP GUARDS IN PLACE.** Ensure guards are in working order.
14. **USE CORRECT TOOLS.** Do not use a tool or attachment to do a job for which it was not designed.
15. **DON'T FORCE THE TOOL.** It will do the job better and be safer at the rate/force for which it was designed.
16. **MAINTAIN TOOLS IN TOP CONDITION.** Keep tools sharp and clean for the best and safest performance. Follow instructions for lubricating and changing accessories.
17. **NEVER STAND ON THE TOOL.** Serious injury could occur if the tool is tipped or if the cutting tool is accidentally contacted.
18. **REMOVE ADJUSTING KEYS AND WRENCHES.** Form a habit of checking to see that keys and adjusting wrenches are removed from tool before turning it on.
19. **DON'T OVERREACH.** Keep proper footing and balance at all times.
20. **DIRECTION OF FEED.** Feed work into the blade or cutter against the direction of rotation.
21. **ATTENTION TO WORK.** Concentrate on your work. If you become tired or frustrated, leave it for awhile and rest.
22. **SECURE WORK.** Use clamps or a vice to hold work when practical. It's safer than using your hand and frees both hands to operate tool.
23. **CHECK DAMAGED PARTS.** Before further use of the tool, any part that is damaged should be carefully checked to ensure that it will operate properly and perform its intended function. Check for alignment of moving parts, binding of moving parts, mounting, and any other conditions that may affect its operation. Any damaged part should be properly repaired or replaced.
24. **DRUGS, ALCOHOL OR MEDICATION.** Do not operate machine while under the influence of drugs, alcohol, or any medication.
25. **DUST WARNING.** The dust generated by certain woods and wood products can be harmful to your health. Always use an approved dust mask and operate machinery in well-ventilated areas. In addition, provide a means for proper dust removal. Use wood dust collection systems whenever possible.

ADDITIONAL SAFETY RULES:



Warning! Failure to follow these rules may result in serious personal injury. **IMPORTANT: THIS REMOTE IS NOT INTENDED FOR USE AS AN EMERGENCY DEVICE AND SHOULD NOT BE RELIED UPON**

1. **DO NOT RELY ON THIS DEVICE AS AN EMERGENCY STOP DEVICE.**
2. **DO NOT OPERATE THE WIRELESS. REMOTE UNTIL IT IS COMPLETELY ASSEMBLED AND INSTALLED.** Follow instructions and recommendations.
3. **REMOTE MUST BE SECURELY FASTENED.** Fasten to either wrist or to the wood lathe with the magnetic back.
4. **DO NOT GET WET.** The remote may be destroyed or become inoperative if it gets wet.
5. **AVOID EXCESS SAWDUST.** Limit sawdust contact with the remote.
6. **FOLLOW ELECTRICAL CODES.** Make sure wiring codes and recommended electrical connections are followed and that the machine is properly grounded.
7. **KEEP WORK AREA CLEAN.** Do not turn the wood lathe on before clearing it of all objects (tools, scraps of wood, etc.). Keep the nearby area and floor clear of debris.
8. **CHECK SET-UP WITH SPINDLE OFF.** Examine the set-up carefully and rotate the work piece, by hand, to check clearance. In addition, check to see speed is correctly selected before turning on spindle.
9. **ALWAYS CHECK CORRECT SPEED IS SELECTED BEFORE SWITCHING ON THE SPINDLE.**
10. **USE LOWEST SPEED** when turning a new or unbalanced work piece.
11. **TURN AT RECOMMENDED SPEED.** Always operate the wood lathe at the recommended speeds. Consult your wood lathe manual for suggested speeds.
12. **WHEN ROUGHING STOCK,** do not jam the wood lathe tool or chisel into work piece or take too big/deep a cut.
13. **DO NOT OPERATE LATHE IF DAMAGED OR FAULTY.** If any part of your wood lathe is missing, damaged or broken, in any way, or if any electrical component fails, shut off the wood lathe and disconnect the wood lathe from the power supply. Replace missing, damaged, or failed parts before resuming the operation.
14. **ADDITIONAL SAFETY INFORMATION.** The instruction for the safe and proper operation of this product is available from the National Safety Council, 444 N. Michigan Avenue, Chicago, IL 60611 in the Accident Prevention Manual of Industrial Operations and also in the Safety Data Sheets provided by the NSC. Also refer to the American National Standards Institute ANSI 01.1 Safety Requirements for Woodworking Machines and the U.S Department of Labor OSHA 1910.213 Regulation.

Installation Instructions:

1. Unpack the two parts from packaging. The small circuit board is the 'Receiver Module' which goes in the control panel of the wood lathe. The watch looking device is the 'Remote'.

Receiver Module (C):

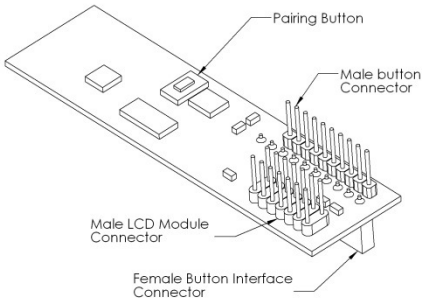

Remote:



1. Turn off the wood lathe and unplug its power cord. Wait 2 minutes for the control circuitry to power down.
2. Remove the Control Panel from the headstock by loosening or removing the 4 screws on both sides of the Control Panel. Gently remove the Control Panel from the head stock.

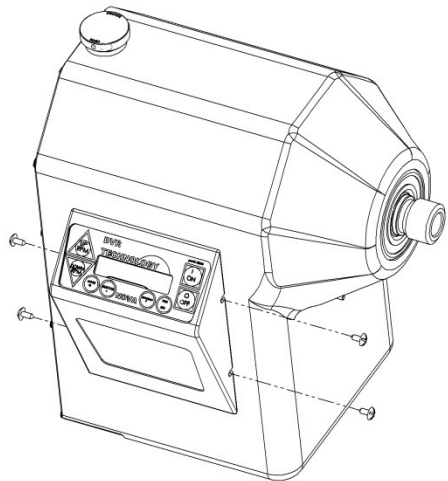

Inside the Control Panel:

3. Disconnect the Motor Controller Cable (A) at (1).

4. Disconnect (B) at (2) and (C) at (3).

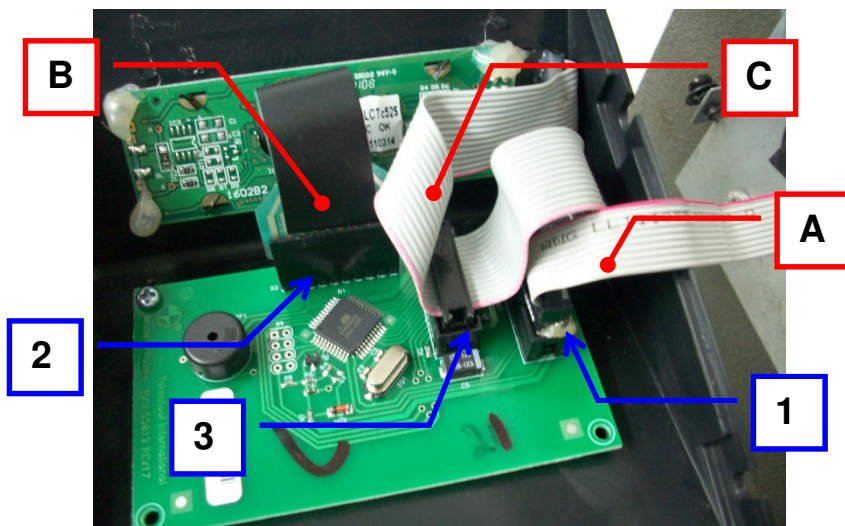

5. Plug the Receiver Module (D) onto (E) by Connecting (4) and (5).

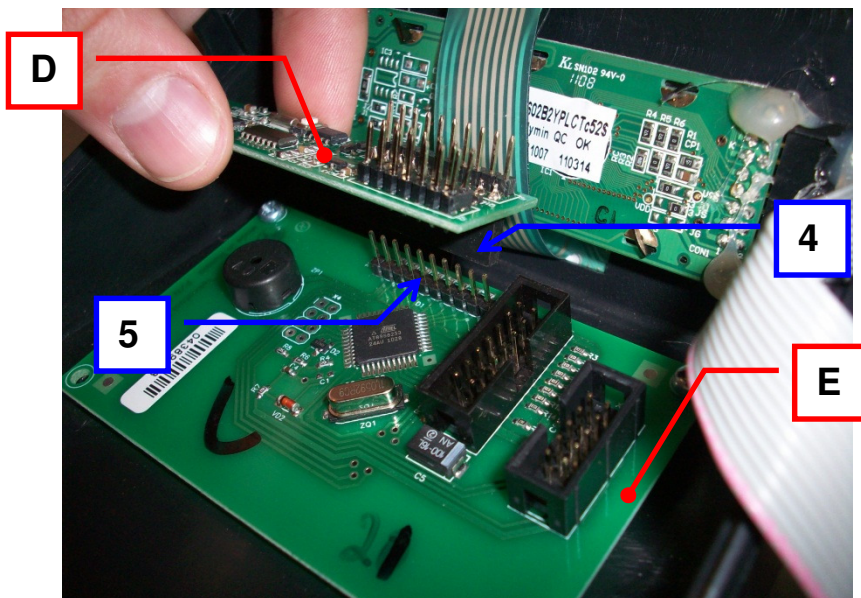

6. Plug (B) into (D), by connecting (2) and (6).

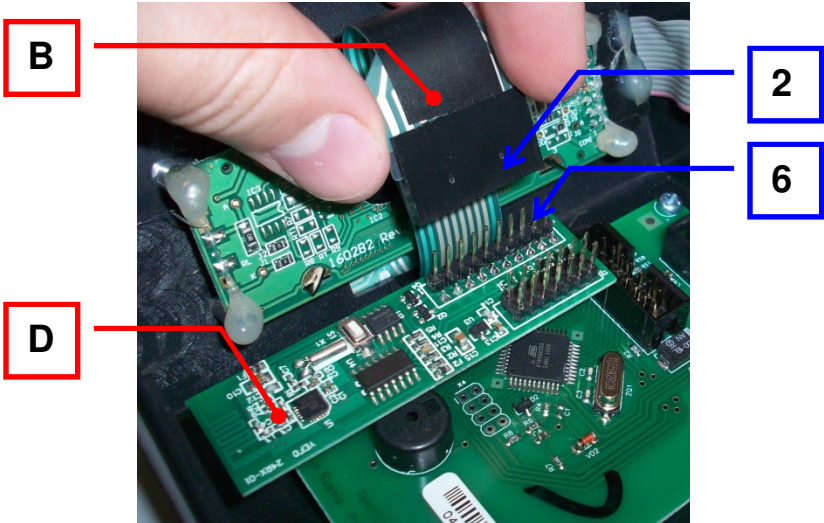

7. Connect Cable (C) to (D) by connecting its middle connector (7) with (8).

Note: Connector (7) must be orientated such that its ribbon cable's red edge faces the larger end of (D) as in the image below.

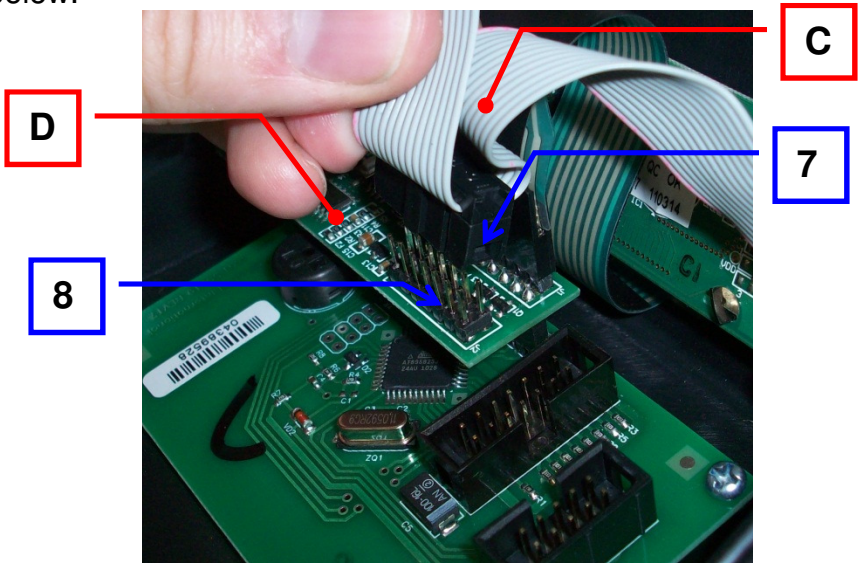

8. Plug the free end of cable (C) into (E), by connecting (8) and (9).

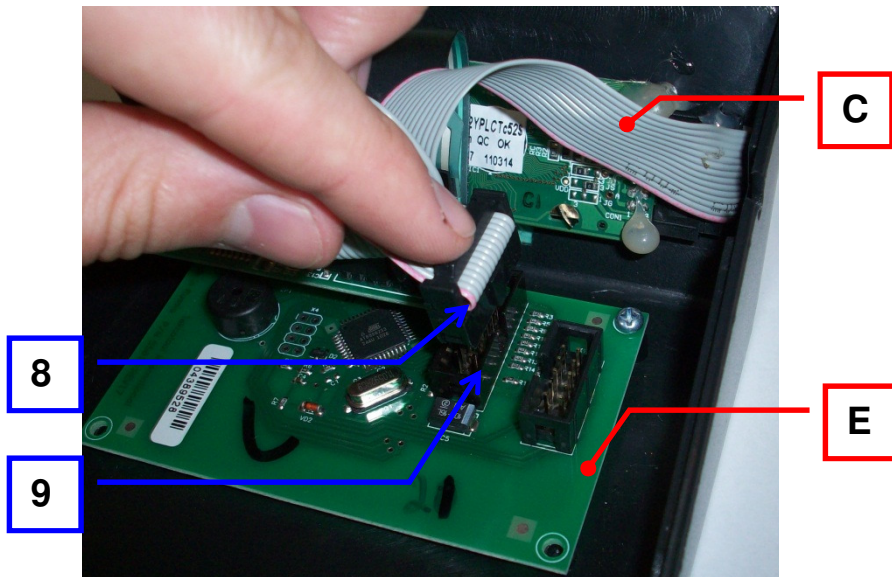

9. Reconnect the Motor Controller Cable (**A**) and check to ensure that all connectors are fully in and in the correct orientation as in the image below.

NOTE: Make sure cable (**C**) is orientated so that its edge is facing the larger end of the receiver module to the left.

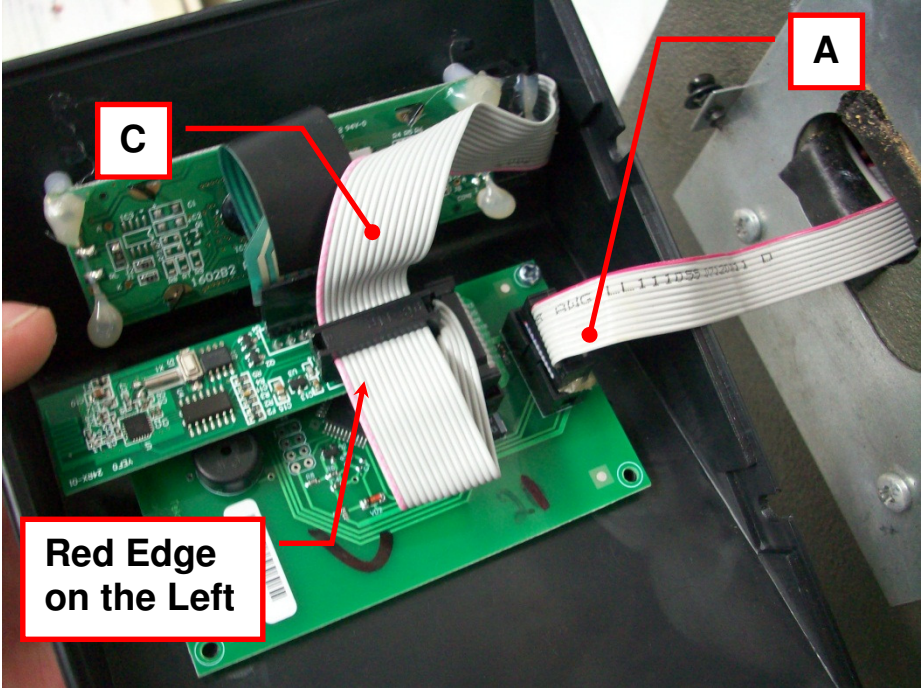

10. Replace the Control Panel on the Headstock and reinstall the four mounting screws (two on each side). Tighten the mounting screws and ensure that the Control Panel is secure.

Remote Button Layout:

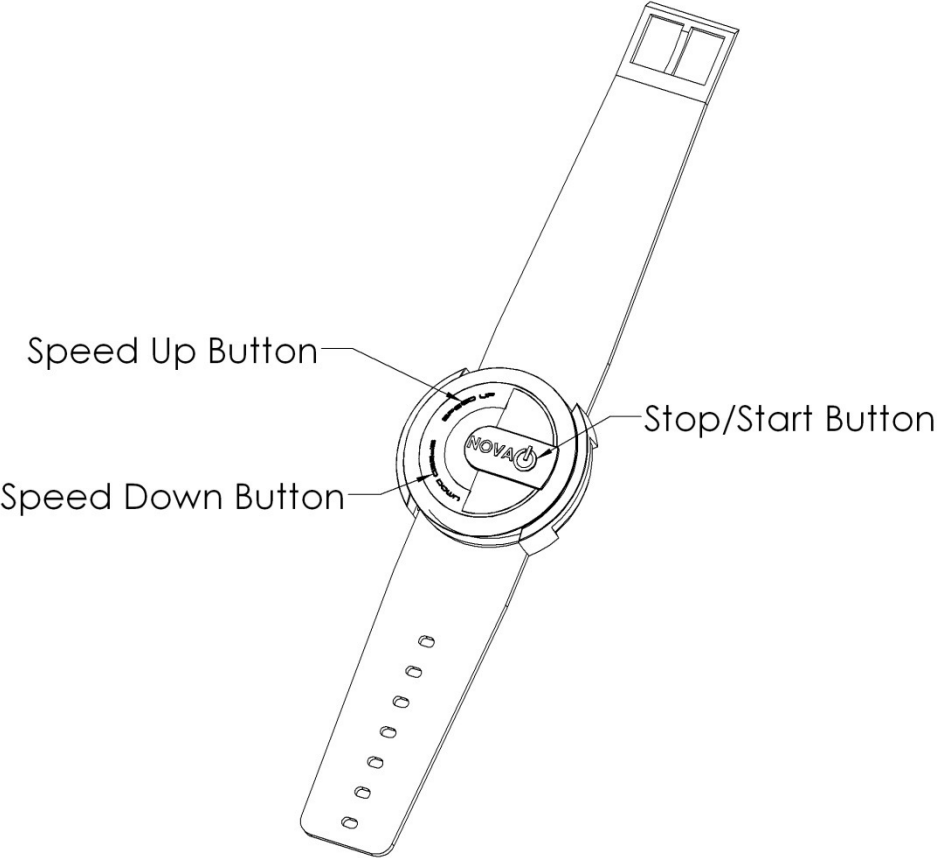

Operating instructions:

Starting and stopping:

To start the lathe with the remote, press and hold the Start/Stop button for 2 seconds.

To stop the lathe, just press and release the Start/Stop button once.

NOTE: The Start/Stop Button is below the power symbol, not the NOVA text.

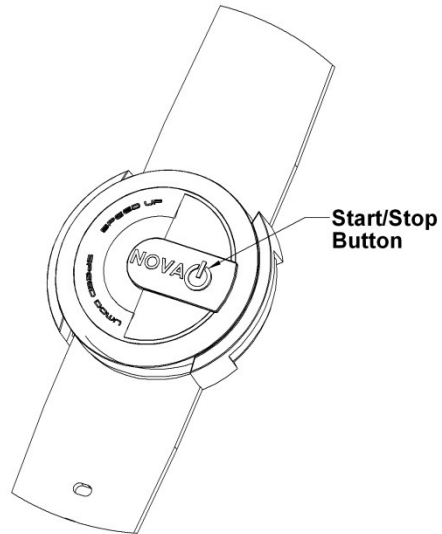

Changing the speed:

To change the operating speed of the wood lathe with the remote, simply press or hold the 'Speed Up' or 'Speed Down' button.

NOTE: When changing the speed, the lathe can be running or stopped. Also, the remote will adjust the speed in 10 or 15 rpm increments.

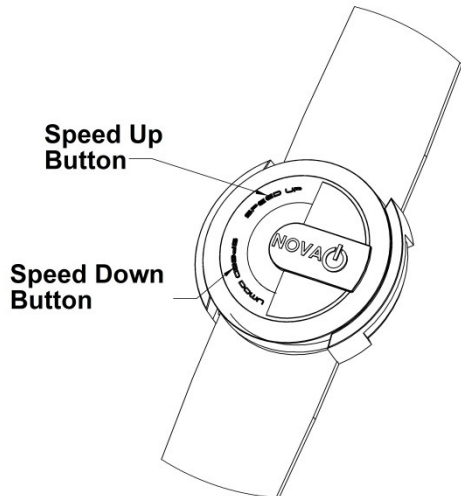

Troubleshooting:

Battery Replacement:

If the battery fails, you can take the remote to a watch repair person to have the battery replaced. The remote will still be paired with or communicate with your NOVA DVR Lathe after battery replacement.

DVR Remote Pairing Instructions

In the event that a new remote or receiver is introduced. The two devices will need to be paired to each other. To do this follow these instructions:

1. Remove the control panel from the headstock by loosening or removing the 4 screws on either side of the control panel. Gently wiggle the Control panel from the head stock. Do not disconnect any of the cables.

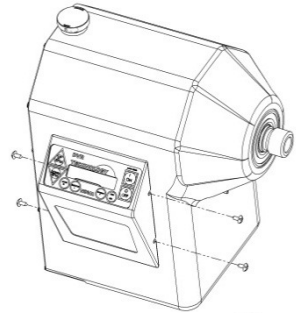

For this step you will need to have the remote you wish to pair with the lathe readily available and have the lathe powered and on but not running.

2. On the Receiver Module there is a small 'Pairing Button' to the left of the connectors. Press the 'Pairing Button' once and then press the remote's 'Start/Stop Button' once within 60 seconds. The control panel should then restart.
3. Replace and screw in the 'Control Panel' on to the headstock. The lathe is now ready for use.

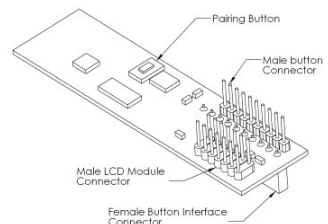
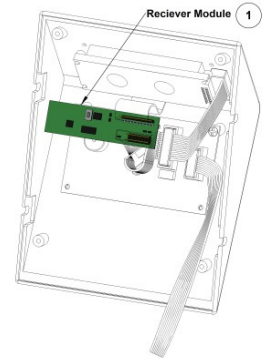

Remote Retro-Fit Kit:

SKU:55519

The NOVA DVR Wireless Remote Retro-Fit Kit enables older DVR Wood Lathes to use the NOVA DVR Wireless Remote. Not required for newer DVR lathes from August 2011 (check for the remote enabled sticker on your DVR lathe bed, if it is present, you don't require the Retro Fit Kit)

Fast and easy to fit with Step-by-Step instructions.

Suitable for all NOVA DVR Lathes.

Available online or through your NOVA Dealer.

www.teknatool.com

© Teknatool® International 2012
All Rights Reserved. Teknatool USA, Inc.



Register your warranty online

www.teknatool.com